

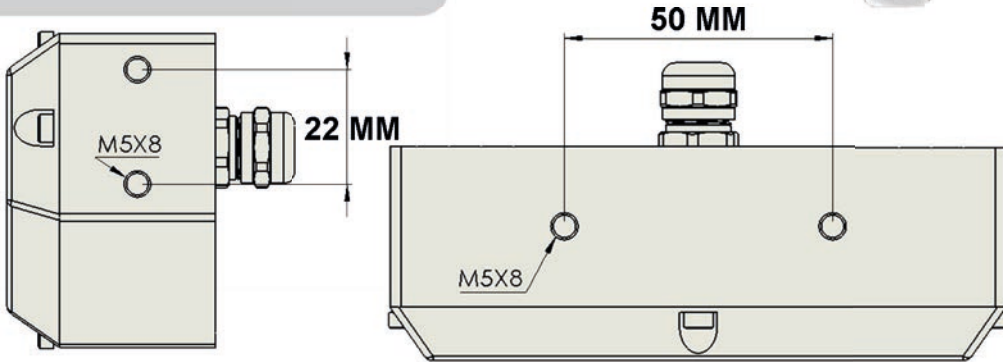

## HEGZA DRIVE LAMP-IR

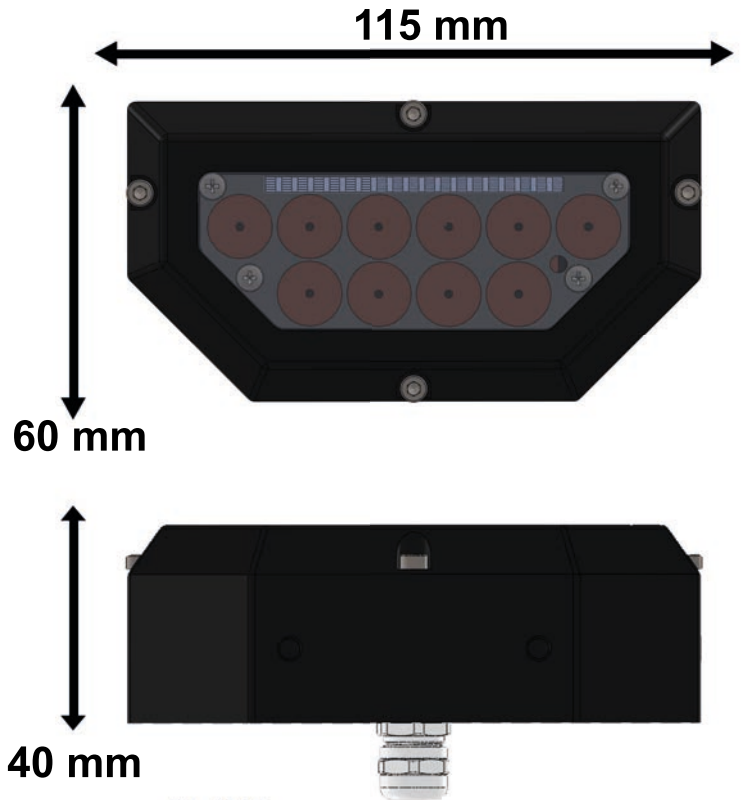

- The driving light combines Blackout and Infrared light in the same body
- 20 meter waterproof
- IP 69K special gasket
- LED technology
- NATO type blackout light
- Symmetrical design for left-right mounting
- Aluminum housing
- MIL-STD 810G
- MIL-STD 461F
- Compliant with UN ECE REGULATION 7
- Free power cable - Optional connector as per requirement



The HEGZA driving light combines Infrared and Blackout in the same body. The HEGZA driving light offers a space-saving and cost-effective solution. With its sealing feature, it is resistant to harsh conditions. Thanks to its symmetrical design, it can be used as both a left and right driving light. It reduces stock costs and eliminates ELD challenges.



R1D-S1D

